

2018 Okoboji Sailing Center Race Series RACE PROGRAM

REVISED JUNE 15, 2018 – VERSION 1.3



OKOBOJI YACHT CLUB SAILING SCHOOL RACE PROGRAM CONTACTS

OFFICERS

President: Tom Rierson
Vice President: Brigid Willkening
Treasurer: Sheryl Jones
Secretary: Judith Thoreson

SCORING & PROTEST COMMITTEES

PRO: Randy Gould
Scoring Manager: Brad Farrar
Chief Judge: Phil Petersen

General Information of Organizing Authority

Okoboji Yacht Club Sailing School, Inc. (OYCSS) / Okoboji Sailing Center (OSC)

Website: <http://www.okobojisailingcenter.org>

Notice Board: <http://www.okobojisailingcenter.org/osc-race-series.html#noticeboard>

Address: 1900 Manhattan Blvd, Spirit Lake, IA 51360

Phone: (712) 337-0121

Executive Director: Brad Farrar

Program Director: Randy Gould (Official Race Office - OYCSS Main Level, East Corner Office)

Optimist Boat, Optimist Team Development Program, and Limited Coaching Registration:

<https://campscui.active.com/orgs/OYCSailingSchool#/selectSessions/2284101/filter/types=1105901> O

OSC Race Series Release and Authorization Form

Attached, Pages 9-10

OKOBOJI YACHT CLUB SAILING SCHOOL, INC.
NOTICE OF RACE (NOR) AND SAILING INSTRUCTIONS (SIs)

1 RULES

- 1.1. The regatta will be governed by the rules as defined in *The Racing Rules of Sailing*.
- 1.2. These NOR and SIs will apply to all races conducted by OYCSSL on West Lake Okoboji except: high school and college racing; training clinics, and the following regatta: 2108 USA Junior Olympic Sailing Festival

2 ELIGIBILITY AND ENTRY

- 2.1. Races are open to all eligible boats of the OYCSSL recognized fleets as part of the OYCSSL training program. This series is an essential part of the OYCSSL training opportunity for our students.
- 2.2. This NOR/SI entitles boats registered in OYCSSL Optimist Racing, *OYCSSL X Boat Racing*, and *OYCSSL 420 programs to be part of each* recognized fleet.
- 2.2. All eligible boats must *register* by delivering a completed entry waiver form to OYCSSL. All entries are subject to acceptance by OYCSSL. It may take up to one week for volunteers to enter a boat into OYCSSL's scoring program.
- 2.3. Eligibility requirements include:
 - 2.3.a. All participants must be in good standing with OYCSSL.
 - 2.3.b. As a condition of eligibility, participant's parents and/or guardian, for themselves and on behalf of their children and minors, will be required to sign a waiver of liability.
- 2.4. OYCSSL recognizes invited guests (e.g., Twin City Youth Sailing, IGLA High School Sailing Club and ILYA members at the discretion of the PRO) are encouraged and eligible to participate in individual events so long as they comply with OYCSSL's directions, rules, waivers, and policies.
- 2.5. Class rules apply to each fleet.
- 2.6 *Competitors within the Optimist Class may use, as part of a class and for a nominal fee, an OYCSSL Opti by registering at: <https://campscui.active.com/orgs/OYCSSailingSchool#/selectSessions/2284101/filter/types=1105901>*

3 NOTICES TO COMPETITORS

- 3.1. Notices to competitors will be posted on the Official Notice Board at: <http://www.okobojisailingcenter.org/osc-race-series.html#noticeboard>
- 3.2. Sailing Instructions will be posted on the Official Notice Board: <http://www.okobojisailingcenter.org/osc-race-series.html#noticeboard> <http://www.okobojisailingcenter.org/osc-race-series.html#NOR>

4 CHANGES TO SAILING INSTRUCTIONS

- 4.1. Any change to the Sailing Instructions will be posted before 0830 on the day it will take effect, except that any change to the schedule of races will be posted by 1700 on the day before it will take effect.

5 SIGNALS MADE ASHORE

- 5.1. Signals made ashore will be displayed from the flag pole located near the lower level patio.
- 5.2. When flag AP is displayed ashore, '1 minute' is replaced with 'not less than 30 minutes' in the race signal AP.

6 SCHEDULE OF RACES

6.1 The Race Schedule is posted at <http://www.okobojisailingcenter.org/osc-race-series.html#schedule>. This schedule shows dates for each race series, time of first warning signal, venue location, events, number of races scheduled, and class and order racing in each series.

15:30 First warning signal, others to follow

Starting Sequence for each individual race:

- 00:00 420 – Main and Jib Only
- 00:03 X Class
- 00:06 Optimist – All Fleets (White/ Blue/ Red)

16:15 No warning signal after this time 16:45

6.2 Wind Conditions for Abandonment are based on the following wind ranges:

Class	Sustained Winds	Wind Gusts
420 Exhibition Class	18 MPH	22 MPH
X	22 MPH	25 MPH
Opti	16 MPH	20 MPH

7 CLASS FLAGS

7.1. Each class flag will be the class insignia on a white background or as stated in the supplement.

8 THE COURSES

8.1. No later than the warning signal, the race committee will designate the course by displaying one or two letters followed by a number, and it may also display the approximate compass bearing of the first leg.

8.2. The course diagrams are on the pages following SI 21. They show the courses, the marks, the order in which marks are to be passed, and the side on which each mark is to be left.

9 MARKS

- 9.1. Marks will be inflatables and not GPS coordinates.
- 9.2. Original marks and change marks will be identified at the competitors' briefing.
- 9.3. After the start, minor adjustments in a mark's location will not be signaled. This changes RRS 33.

9.4. An offset mark may be set approximately adjacent to a windward mark. Offset mark is a mark of the course for all courses, which must be rounded to port after rounding the windward mark.

9.5. When a mark is changed, the new mark may have a different shape and/or color.

9.6. Government navigation buoys, except "SLOW" or "NO WAKE" buoys, are marks of the course and must be obeyed.

10 THE START

10.1. Races will be started by using a three minute starting sequence, this changes RRS 26.

10.2. The starting line will be between a staff displaying an orange flag on the race committee vessel (RC) and the course side of the starting mark.

11 CHANGE OF THE NEXT LEG OF THE COURSE

11.1. To change the next leg of the course, the race committee will lay a new mark (or move the finishing line) and remove the original mark as soon as practicable. When in a subsequent change a new mark is replaced, it will be replaced by an original mark.

12 THE FINISH

12.1. The finishing line will be between a staff displaying an orange flag on the race committee vessel (RC) and the nearest course side of the finishing mark.

13 TIME LIMITS

13.1. The following time limits will apply and, for each, the time limit is:

- Mark 1 Time Limit of 20 minutes for the first boat to pass Mark 1.
- Race Time Limit of 45 minutes for the first boat to sail the course and finish.
- Finishing Window time limit of 15 minutes for boats to finish after the first boat sails the course and finishes.

13.2. If no boat has passed Mark 1 within the Mark 1 Time Limit, the race shall be abandoned.

13.3. Boats failing to finish within the Finishing Window shall be scored Did Not Finish (DNF) without a hearing. This changes RRS 35, A4 and A5.

14 PROTESTS AND REQUESTS FOR REDRESS

14.1. Protest forms are available at the race office. Protests and requests for redress or reopening shall be delivered there within the appropriate time limit.

14.2. For each class, the protest time limit is 30 minutes after the last boat has finished the last race of the day or the race committee signals no more racing today, whichever is later.

14.3. Notices will be posted no later than 30 minutes after the protest time limit to inform competitors of hearings in which they are parties or named as witnesses and where the hearings will be held.

14.4. Notices of protests by the race committee, technical committee or protest committee will be posted to inform boats under RRS 61.1(b).

14.5. After the last scheduled race of the day a request for redress based on a protest committee decision shall be delivered no later than 30 minutes after the decision was posted. This changes RRS 62.2.

15 DISCLAIMER OF LIABILITY AND RELEASE

Sailing is an activity that has an inherent risk of damage and injury, including without limitation bodily injury, permanent disability and death. Each person participates in each race entirely at his/her own risk. See RRS *Rule* 4, "Decision to Race".

ORGANIZING AUTHORITY, RACE COMMITTEE, PROTEST COMMITTEE, FLEETS, SPONSORS, OKOBOJI YACHT CLUB SAILING SCHOOL, INC., OKOBOJI YACHT CLUB, HOST CLUB AND VENUE (AND EACH OF THEIR RESPECTIVE OFFICERS, DIRECTORS, PERSONNEL, EMPLOYEES, CONTRACTORS, OFFICIALS, MEMBERS, GUESTS, VOLUNTEERS, AGENTS, REPRESENTATIVES AND ALL OTHER PERSONS IN THEIR CAPACITY OF ASSISTING A RACE OR RELATED EVENT OR ACTIVITY) (COLLECTIVELY, "RACE ORGANIZERS") WILL NOT BE RESPONSIBLE OR LIABLE FOR ANY ACTION, CLAIM, LIABILITY, LOSS, DAMAGE, ACCIDENT OR INJURY (INCLUDING BODILY INJURY, PERSONAL INJURY, PERMANENT DISABILITY OR DEATH) (COLLECTIVELY, "DAMAGES") TO ANY PERSON, PROPERTY OR BOAT (I) SUSTAINED IN CONJUNCTION WITH OR PRIOR TO, DURING, OR AFTER EACH RACE; OR (II) ARISING, RELATING OR RESULTING FROM USE OF RACE FACILITIES OR PARTICIPATION IN A RACE OR ASSOCIATED EVENT OR ACTIVITY, TO THE FULLEST EXTENT PERMITTED BY LAW.

By participating, each participant's parent and/ or guardian and each participant (in the case of children and minors) forever releases, discharges and waives any and all actions, suits and claims whatsoever against Race Organizers for any Damages to any person, property or boat (i) sustained in conjunction with or prior to, during, or after each race; or (ii) arising, relating or resulting from use of race facilities or participation in a race or associated event or activity, to the fullest extent permitted by law. Each participant's parent and/ or guardian and each participant further releases all Race Organizers from any Damages whatsoever on account of any of them giving assistance, aid, care, advice, rescue, first aid, treatment or services.

16 INSURANCE

Each participating boat owned or leased by the participant's parent and/ or guardian will be insured with valid third-party liability insurance as required by OYCSS. Each boat will present proof of insurance upon request.

17 GOVERNMENTAL RULES

Each participating boat owned or leased by the participant's parent and/ or guardian will have safety gear, proper registration and display licenses and numbers as required by law.

18 ADDITIONAL BOAT REQUIREMENTS

18.1. All boats are required to race with floatation, and in the case of the X Class addition of a sail panel, in their proper placement.

18.2. A boat is not required to display a US Sailing-assigned sail number and national letters. Hull numbers and customary sail numbers are permitted. This changes RRS *Rule* 77 and Appendix G.

- 18.3. A boat new to her class whose sail number duplicates an existing sail number in her class will change the number on all sails so there are no duplications. This changes RRS Rule 77 and Appendix G.
- 18.4. While racing, a boat must display its sail number on its mainsail.
- 18.5. A boat using a borrowed or other sail not carrying its proper number must report the discrepancy to the RC both before and after each race where the mis-numbered sail is used.

19 PRIZES

19.1. Prizes will be given for top 3 places in each fleet in the series for the following fleets:

- OPTI (RWB Combined)
- X Class

19.2. Special Awards may be given during the series.

20 PUBLICITY & PHOTOGRAPHER'S RIGHTS

As a condition of participation, each parent and/or guardian of each participant (on behalf of their children/minors) grants Race Organizers and their designated photographers the perpetual, irrevocable right, license and permission to use, publish and distribute the participant's name, photos, video, images, finishes, results and statements of them and their boat and crew in all forms and media worldwide (including without limitation Internet) for any purposes whatsoever (including without limitation advertisement, promotions, public sale of pictures, etc.) without compensation or further permission.

21 ORGANIZING AUTHORITY & HOST CLUB

Organizing Authority and host is the Okoboji Yacht Club Sailing School, Inc. located at 1900 Manhattan Blvd, Spirit Lake, IA 51360. For further information, contact Randy Gould by calling (712) 337-0121 or emailing OkobojiSailingCenter@gmail.com.



COURSE DIAGRAMS

W

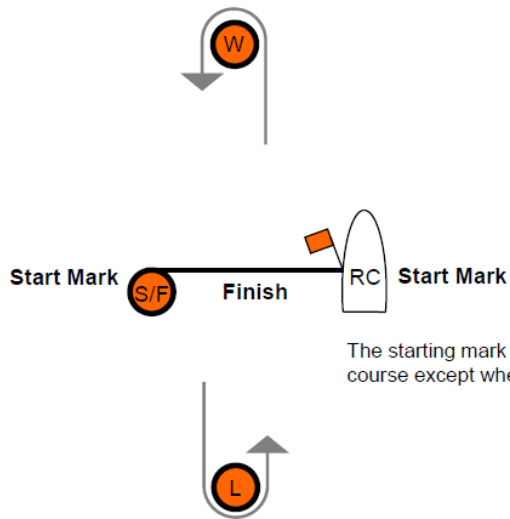

Courses* - "Windward – Leeward Midline"	
Signal	Mark Rounding Order
W1	Start – W – L – Finish
W2	Start – W – L – W – L – Finish
W3	Start – W – L – W – L – W – L – Finish

The starting mark and RC are not marks of the course except when starting and finishing.

Leave marks to port.

*Diagram is not to scale

WL & M

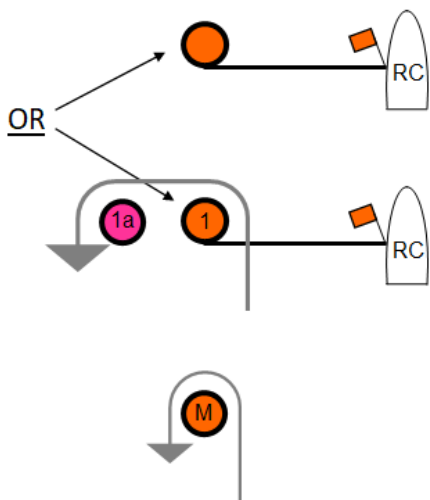

Courses* - "Windward – Leeward Gates"	
Signal	Mark Rounding Order
WL2	Start – 1 – 1a – Leeward Finish
WL3	Start – 1 – 1a – 2S/2P – Windward Finish
WL4	Start – 1 – 1a – 2S/2P – 1 – 1a – Leeward Finish
WL5	Start – 1 – 1a – 2S/2P – 1 – 1a – 2S/2P – Windward Finish
M2	Start – M – Leeward Finish
M3	Start – M – 2S/2P – Windward Finish
M4	Start – M – 2S/2P – M – Leeward Finish
M5	Start – M – 2S/2P – M – 2S/2P – Windward Finish

Windward finishes may be at mark 1 or may be located windward of mark 1. Mark 1 is not a mark of the course for boats sailing to a finish line windward of mark 1.

The Start Line for all fleets is between the **RC Flag** and mark **2P**.

Gate mark **2S** may not be in position before the start. In the case 2S is not in place, competitors will round **2P** to port.

Leave all marks to port, except boats may round **2P** to port or **2S** to starboard after passing through the leeward gate.

Leeward Finish will be between RC and nearest mark.

*Diagram is not to scale

TL

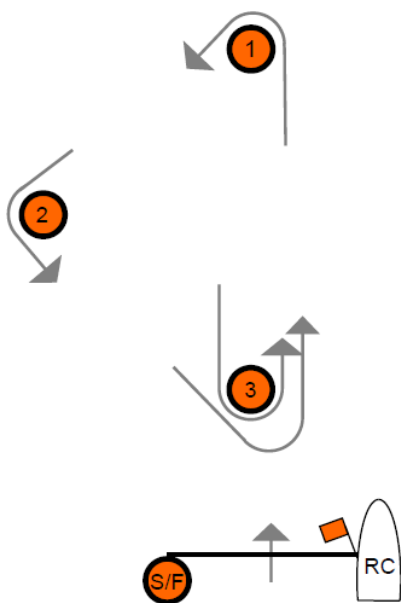

Courses* - "Triangle, Leeward Finish"	
Signal	Mark Rounding Order
TL2	Start – 1 – 2 – 3 – 1 – Finish
TL3	Start – 1 – 2 – 3 – 1 – 3 – 1 – Finish
TL4	Start – 1 – 2 – 3 – 1 – 3 – 1 – 3 – 1 – Finish

The Start Line for all fleets is between the **RC Flag** and mark **2P**.

Gate mark **2S** may not yet be in position before the start.

Leave all marks to port, except boats may round **2P** to port or **2S** to starboard after passing through the leeward gate.

*Diagram is not to scale

TW

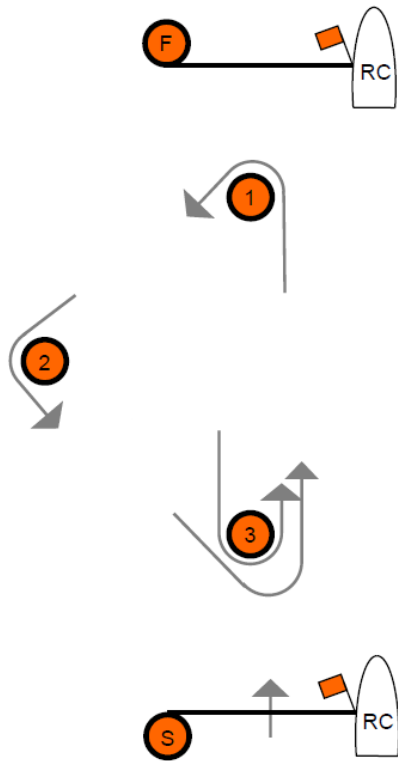

Courses* - "Triangle, Windward Finish"	
Signal	Mark Rounding Order
TW2	Start - 1 - 2 - 3 - 1 - 3 - Finish
TW3	Start - 1 - 2 - 3 - 1 - 3 - 1 - 3 - Finish
TW4	Start - 1 - 2 - 3 - 1 - 3 - 1 - 3 - 1 - 3 - Finish

Windward finishes may be at mark 1 or may be located windward of mark 1. Mark 1 is not a mark of the course for boats sailing to a finish line windward of mark 1.

The Start Line for all fleets is between the **RC Flag** and mark **2P**.

Gate mark **2S** may not yet be in position before the start.

Leave all marks to port, except boats may round **2P** to port or **2S** to starboard after passing through the leeward gate.

*Diagram is not to scale

2018 OKOBOJI SAILING CENTER RACE SERIES AUTHORIZATION AND RELEASE

STUDENT: _____

Emergency Treatment Authorization

I/We the undersigned parent, parents, or legal guardian of this child, a minor, do hereby authorize and consent to any x-ray, examination, anesthetic, medical diagnosis rendered under the general or special supervision of any member of the medical staff licensed under the provisions of the Iowa Code chapters related to the Iowa Board of Medicine or a dentist licensed under the Iowa Code that is regulate by the Iowa Dental Board and on the staff of any acute general hospital from the State of Iowa Department of Human Services. It is understood that this authorization is give in advance of any specific diagnosis, treatment, or hospital care being required but is given to provide authority and power to render care which the aforementioned physician in the exercise of his best judgment may deem advisable. It is understood that effort shall be made to contact the undersigned prior to rendering treatment to the patient, but that any of the above treatment will not be withheld if the undersigned cannot be reached.

Emergency Contact A: _____ Phone: _____

Emergency Contact B: _____ Phone: _____

Initials: _____

Media Rights

Participants at the Okoboji Yacht Club Sailing School, Inc. give absolute right and permission for video footage or photographs of themselves generated during an Okoboji Yacht Club Sailing School, Inc. event or class to be published in any media for press, editorial or advertising purposes.

Initials: _____

Release

The undersigned parent/guardian recognizes that an element of risk is involved in all water sports, including sailing. Therefore, to induce the Okoboji Yacht Club Sailing School, Inc. to accept his/her child into the Okoboji Yacht Club Sailing School, Inc., the undersigned parent/guardian covenants and agrees to hold harmless and indemnify the Okoboji Yacht Club Sailing School, Inc. or the Okoboji Yacht Club, their officers, directors, employees, and agents from any and all claims, losses, damages, fees and liability growing out of or in any manner related to injury to a person or damage to any property arising out of or in anywise connected with the operation of the Okoboji Yacht Club Sailing School, Inc. or any activities on or the use of any facilities or equipment of Okoboji Yacht Club Sailing School, Inc.

Initials: _____

Certification of Swimming Skills

I/We the undersigned parent, parents, or legal guardian, do hereby certify the student enrolled can swim for 40 yards with a secured PFD, can tread water for one minute, and is comfortable in and around the water.

Initials: _____

Parental/ Legal Guardian Agreement

I/We understand that I/we are responsible for the competitor’s behavior and conduct while at the Okoboji Yacht Club Sailing School, Inc. and participating in Okoboji Yacht Club Sailing School, Inc events and will see to it that our child adheres to the program rules. I/We agree to assume the obligation for expenses of repair and/or replacement of program equipment that is attributed to our child’s reckless or irresponsible behavior and the expense of medical care if our child is injured. I/We agree to make an appointment for a parent/instructor or coach conference if requested.

Initials: _____

State Mandated Youth Sports Concussion Information

The Okoboji Yacht Club Sailing School, Inc. subscribes to the practices mandated by the State of Iowa that all youth sports programs comply with the Iowa High School Athletic Association’s requirements that information and guidelines provided by the Center for Disease Control be distributed for concussion. Students and their parents/legal guardians are required to acknowledge and sign the “HEADS UP: Concussion in High School Sports” fact sheet attached. More information is available at on the CDC website: <https://www.cdc.gov/HeadsUp/>

All Okoboji Yacht Club Sailing School, Inc. staff will complete the CDC's 'Heads Up: Concussion in Youth Sports' training for coaches: <https://www.cdc.gov/headsup/highschoolsports/coach.html>

If a concussion is suspected, all Okoboji Yacht Club Sailing School, Inc. staff follow the CDC approved 'Heads Up four-step action plan':

- 1. Remove participant from activity immediately
- 2. Ensure that the participant is evaluated by an appropriate healthcare professional
- 3. Inform the participant's parents or guardians
- 4. Keep the participant out of play

Initials: _____

- For specific information please see “HEADS UP: Concussion in High School Sports” Fact Sheet: https://www.cdc.gov/headsup/pdfs/youthsports/parents_eng.pdf

Indicate Agreement

I agree to all of the above statements.

Printed Name

Relationship to Student

Parent, Parents, or Legal Guardian Signature

Date